

Part II: Plug & slot welding symbols

57

A. Plug Weld Symbol

A plug weld is a round weld made through a hole in one piece of metal, welding that piece to another. The plug weld size is placed to the left of the plug weld symbol and is preceded by the *diameter symbol* Φ .

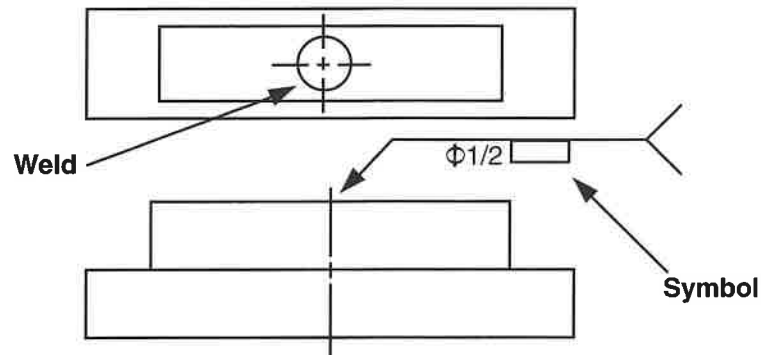

Draw the symbol for a *plug weld* with a *diameter* of $5/8$ inch on the *arrow side* of the joint.



The place where the plug weld should be deposited, is shown by the center line through the drawing which meets the arrow. The drawing may show a locating dimension.

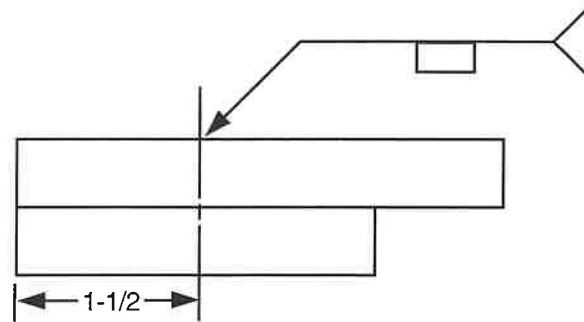

Draw a symbol for a *plug weld* on the *arrow side*, 3 inches from the side of the weldment. Show the locating dimension.



The *included angle of countersink* is shown under the symbol for the arrow side (or above the symbol for the other side). The included angle of countersink is the angle formed by the sides of the hole. The *diameter* of the weld is the diameter at the bottom of the hole.

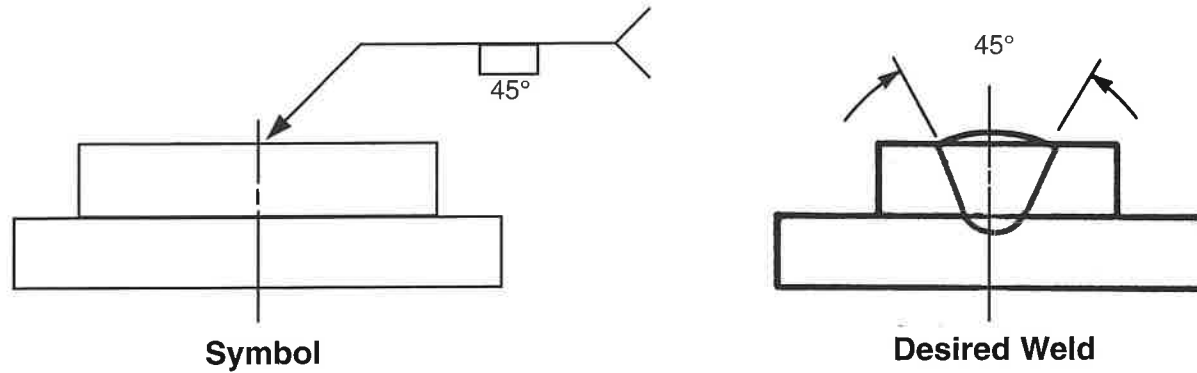

Note: If no countersink is desired, then 0° should be used as the angle value.

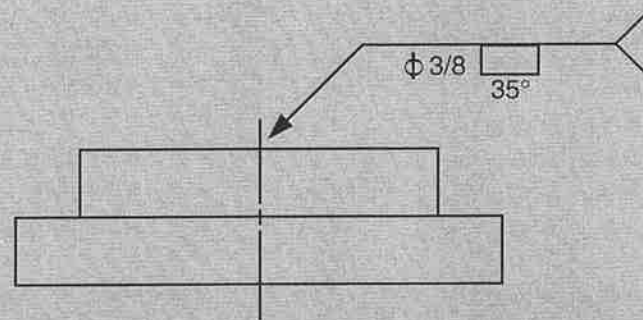

1. This is a _____ weld symbol.
2. The angle of countersink is _____.
3. The diameter of the weld is _____.

Important:

If no angle is shown, the angle will be the manufacturer's (user's) standard angle. The user's standard is a uniform shop procedure for completion of repetitive tasks, such as preparation of joint edges and finishing weld profiles. These standards are employed unless otherwise noted in the welding symbol or welding procedure.

When a definite number of plug welds is desired in a joint, the number shall be specified in parentheses on the same side of the reference line as the weld symbol.

Interpret the weld symbol:

1. Type of weld _____
2. Size of weld _____
3. Number of welds _____
3. Angle of countersink _____

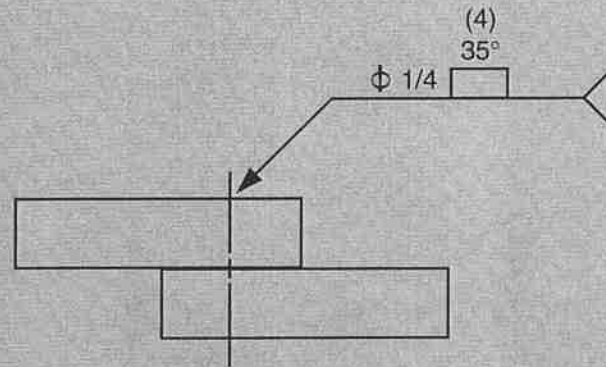

A fractional dimension inside the plug weld symbol indicates the depth of filling. A plug weld will be filled completely if no depth of filling is given.

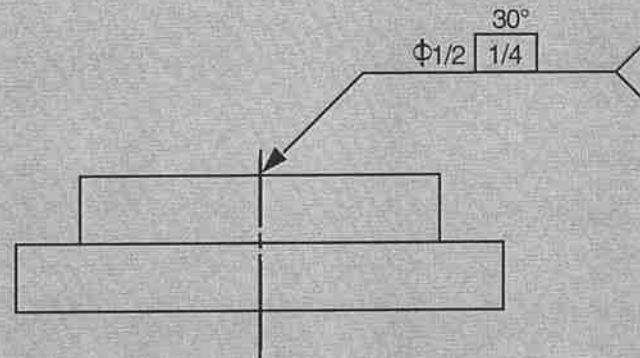
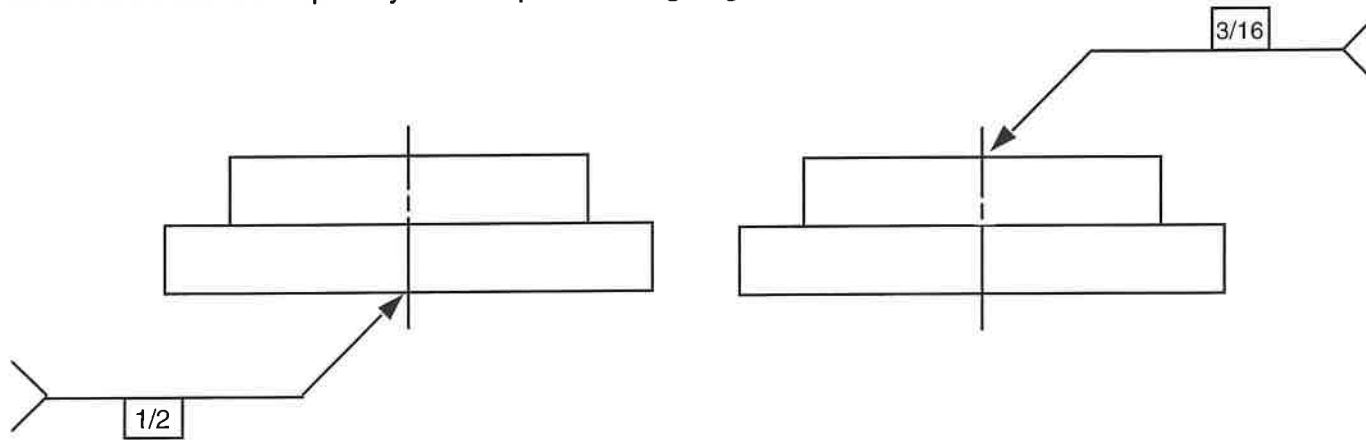

This _____ weld will have a _____ depth of filling, a _____ diameter at the bottom, and a _____ countersink angle.

When the welding symbol also includes the angle of countersink, the *number of plug welds* shall be placed either *above* or *below* the angle of countersink as appropriate.

The *pitch* (center-to-center spacing) of the plug welds is shown to the *right* of the symbol.

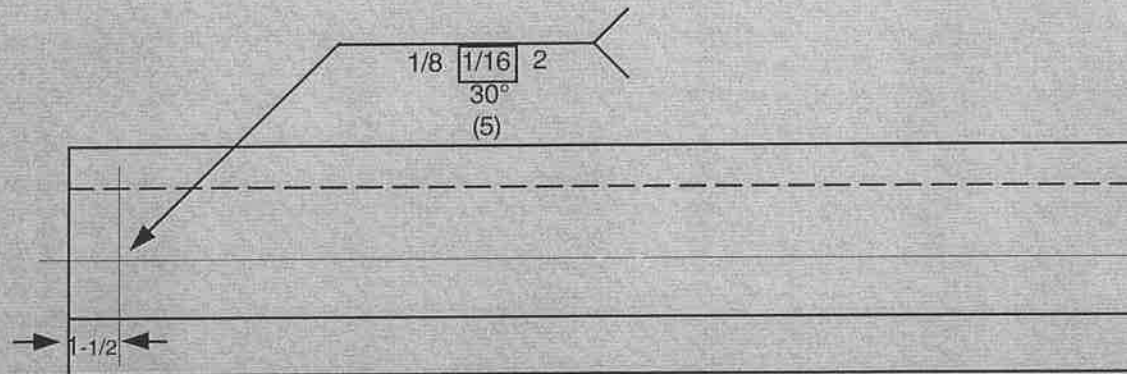
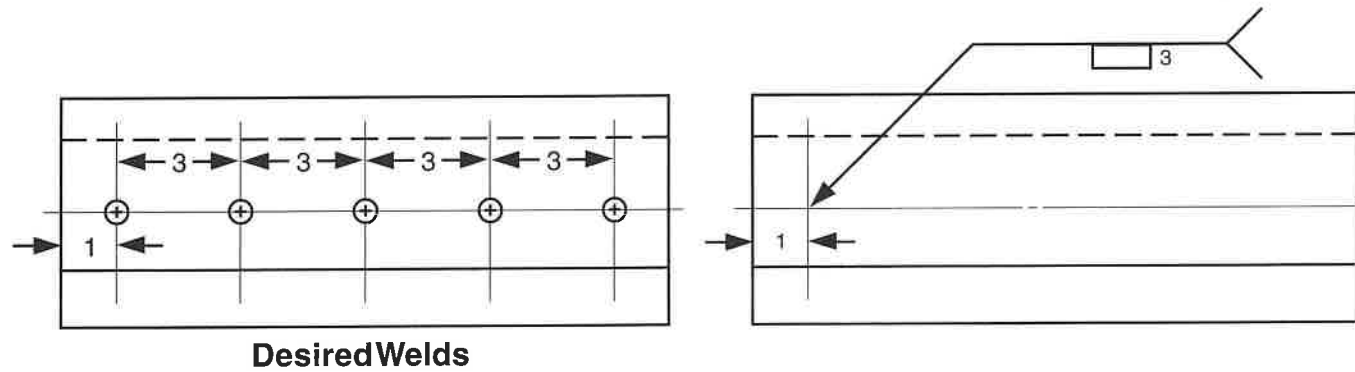

This plug weld will have a pitch of _____, a diameter of _____, a filling of _____, and a countersink angle of _____. The number of welds is _____.

The *contour* symbol and *finish* method are shown *above* the plug weld symbol for the *other side* and *below* the plug weld symbol for the *arrow side*.

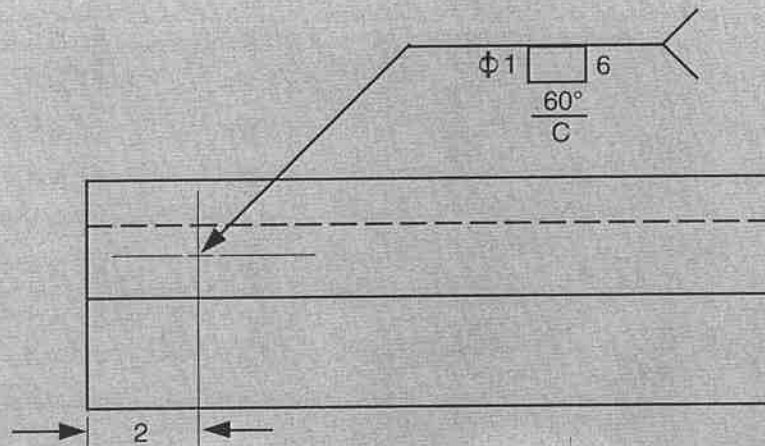
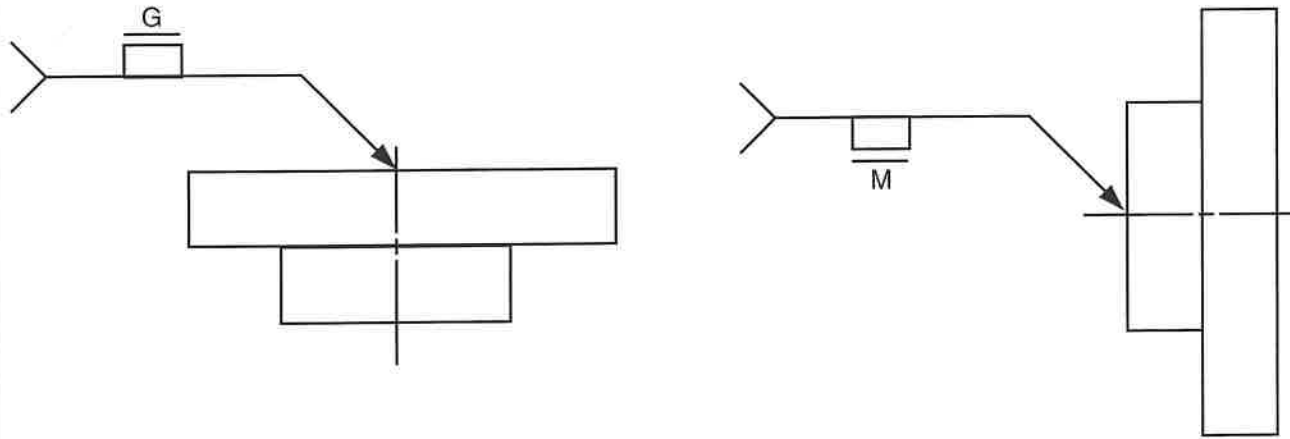

The plug welds will have a _____ contour, a _____ diameter, a _____ angle of countersink, a _____ pitch and be finished by _____.

The first plug weld will be placed _____ from the left.

Plug welds to be made flush without mechanical finishing require the flush symbol only.

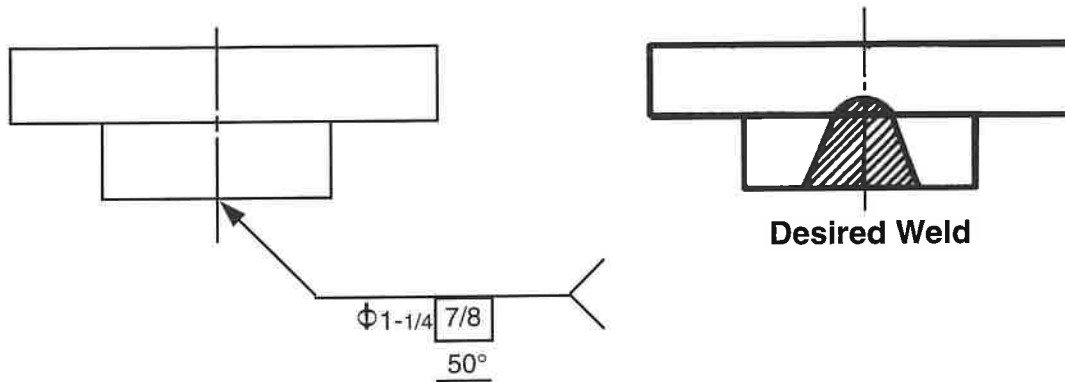

Note: If welds require a flat but not flush surface, an explanatory note is included in the tail of the welding symbol.

Draw the symbol for a *plug* welds with *diameter* of 1/2 inch on the *arrow side* of the joint. The *angle of countersink* is 30° and the weld is to be produced *flush*.

